



JOHN DEERE

3 5 M E T R I C T O N

D

EXCAVATOR

350D LC





Armed, willing, and stable.

When you're ready to pull the trigger on greater productivity, arm yourself with the new 350D LC. Delivering the exceptional power, smoothness, and control you've come to expect from John Deere, this highly capable 35-metric-ton excavator is bigger and stronger than ever. Tougher, too,

with a beefier undercarriage, an even more efficient cooling system, and a rugged Tier III diesel. Add in other refinements such as faster hydraulics, better visibility, and a quieter, more spacious cab, and you've got all the firepower you need for maximum productivity and uptime.



Extended engine and hydraulic fluid-service intervals simplify maintenance and reduce daily operating costs.

Redesigned cab combines more legroom and 47-percent more glass for unsurpassed comfort and visibility.

Powerwise™ III engine/hydraulic management system maximizes power output, saves fuel, and delivers smooth multifunction hydraulic operation.

Hydraulically driven fan runs only as needed, reducing noise, fuel consumption, and operating costs.

Fuel-efficient Tier III emission-certified PowerTech Plus™ diesel delivers power without compromise in all conditions.

Specifications

350D LC

SAE Net Horsepower.....	271 hp
Operating Weight.....	77,269 lb.
Lift Capacity.....	19,413 lb.
Digging Depth.....	26 ft. 10 in.
Arm Breakout Force.....	32,682 lb.

350D LC goes about its business quietly. Its variable-speed fan, dual-pass muffler, pilot-injected PowerTech Plus engine, and isochronous high-idle speed help quiet things down.

Cooled exhaust gas recirculation (EGR), four-valve-per-cylinder head, and high-pressure common-rail fuel system enable the 9.0-L diesel to meet Tier III emission standards without sacrificing power or fuel efficiency.

Additional capability a necessity? High-pressure high-flow auxiliary hydraulic packages, plus a variety of track widths, arm lengths, buckets, and other options enable you to meet your needs.

Machine Information Center (MIC) captures and stores vital machine performance and utilization data to help improve productivity, uptime, and profit.

Short-throw low-effort pilot controls, best-in-class metering, and superb multifunction operation deliver big payloads with smooth finesse.

1. Need a little extra hydraulic power to overcome tough going? Simply press the power-boost button on the right-hand control and muscle through.
2. Electronically controlled variable-geometry turbocharger (VGT) improves torque response, helping match engine speed to load requirements.
3. Powerwise III perfectly balances engine performance and hydraulic flow for smooth, predictable operation. One work mode makes it easy to be productive in any application.

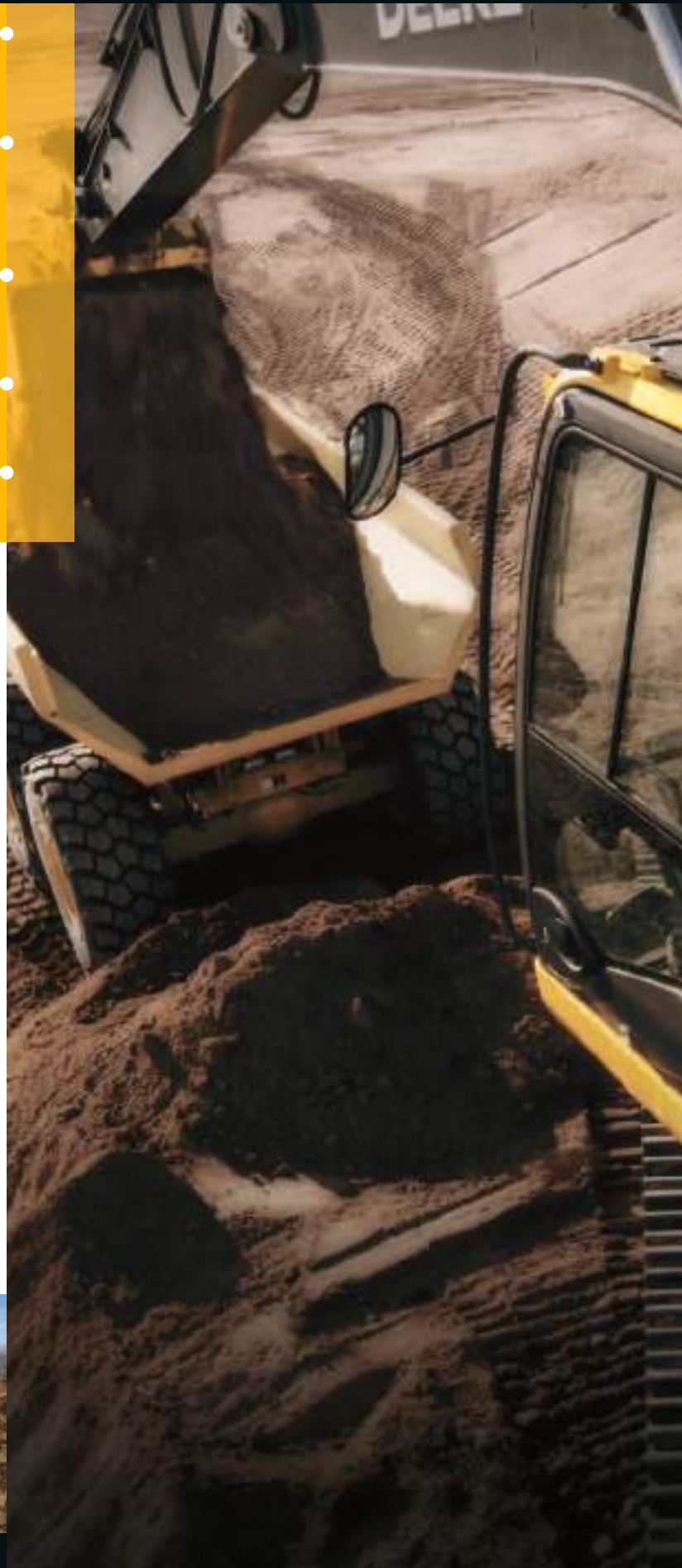



Put more work within reach.

Whether you're excavating, loading trucks, or laying pipe, the 350D LC delivers the performance you need to get more done. Faster hydraulics and significant increases in horsepower, lift capacity, swing torque, and drawbar pull provide the ability, while additional weight

and a bigger undercarriage provide ground-gripping stability. But for all its added muscle, the 350D LC gets things done with typical Deere finesse. Its Powerwise III engine/hydraulic management system provides pinpoint metering for effortless, smooth-as-silk control.

The image shows the interior of a 350D LC excavator cab. The view is from the operator's perspective, looking towards the front. The cab is equipped with a large, high-velocity automatic climate-control system, a heated seat, and various amenities. The controls are visible, including a joystick and several buttons. The overall environment is designed for comfort and efficiency.

An exceptional environment for exceptional operators.

Want to bring out your operators' best? Put them inside the most comfortable and efficient operating environment on any excavator. The 350D LC's spacious, sound-suppressed cab provides quiet sanctuary, substantial legroom, and virtually unobstructed visibility.

A high-velocity automatic climate-control system and available air-suspension heated seat ensure year-round comfort. Additional amenities include AM/FM radio, 12-volt power port, hot/cold box for beverages, and generous storage for carryons, to list just a few.



Deluxe-suspension multi-position seat has 10½ inches of travel, sliding together or independently of the control console. So it won't cramp an operator's style.

Ergonomically designed short-throw pilot levers provide smooth, predictable fingertip control with less movement and effort.

Pushbuttons in the right lever allow fingertip control of auxiliary hydraulic flow for operating attachments.

Convenient 12-volt port powers cell phones and other electronic devices.

Redesigned cab isn't just roomier, it's also noticeably quieter and more comfortable. Silicone-filled mounts effectively isolate operators from noise and vibration.

1. Wide expanse of glass, narrow front cab posts, overhead hatch, and numerous mirrors provide virtually unobstructed all-around visibility.
2. No shortage of storage in here. There's a place for a cooler, cup holders, and even a hot/cold beverage box that keeps refreshments at just the right temperature.
3. Automatic, high-velocity bi-level climate-control system with automotive-style adjustable louvers helps keep the glass clear and the cab comfortable. AM/FM radio comes standard, too.
4. Intuitive, multi-language monitor provides a wealth of machine info and control. Its four-color LCD screen displays operating, diagnostic, and maintenance info with easy-on-the-eyes clarity.



Graphite-iron wet-sleeve cylinder liners, mono-steel pistons, and large-diameter connecting rods ensure long-term engine durability.

Perforations in the hood and side shields serve as a "first filter," helping prevent trash entry. Anything that passes through will also clear the eight-fin-per-inch cooler cores.

Hydraulically driven fan runs only as needed, reducing fuel consumption and debris flow through the coolers.

Optional reversing fan back-blows cooler cores to reduce debris buildup. It's a welcome addition that will increase uptime.

Tungsten-carbide coating creates an extremely wear-resistant surface to protect the all-important bucket-to-arm joint.

Oil-impregnated bushings enhance durability and extend grease intervals to 500 hours for the arm-and-boom joint and 100 hours for the bucket joint.



1. With large idlers, carrier and bottom rollers, heavier links, and 12 track guides, the significantly beefed-up undercarriage delivers long and reliable performance.



2. Reinforced resin thrust plates, grooved bushings, and thermal-coated bucket joints increase arm and boom lube intervals to 500 hours.

3. Welded bulkheads within the boom resist torsional stress. Reinforced D-channel side frames provide maximum cab and component protection.

4. Highly efficient, heavy-duty cooling system keeps things cool, even in tough environments or high altitudes.

5. Large box-section track frames, thick-plate single-sheet mainframe, and massive swing bearing deliver rock-solid durability.





Nothing runs like a Deere because nothing is built like one.

It's a tough world out there. Fight back, with the 350D LC. Like all Deere D-Series Excavators, it's built to the max for long-term durability. So tough, in fact, that its boom, arm, and mainframe are warranted for three years or 10,000 hours. Other uptime-

boosting features include wet-sleeve engine liners, tungsten-carbide thermal-coated surfaces, oil-impregnated bushings, welded boom bulkheads, and extended engine and hydraulic service intervals. When you know how they're built, you'll run a Deere.

Large easy-to-open doors provide quick access to service items. Lube banks, filters, and checkpoints are grouped for added convenience.

Machine Information Center captures and stores vital machine performance and utilization data to help improve uptime, productivity, and profit.

Auto-idle helps make the most of every drop of precious fuel by automatically reducing engine speed when hydraulics aren't in use.

Large fuel tank and 500- and 5,000-hour engine and hydraulic oil service intervals decrease downtime for routine maintenance.

Nobody backs you better than the 500-plus John Deere dealers throughout North America.



Super-size uptime, downsize operating costs.

If there's a way to increase uptime and reduce daily operating costs, we've implemented it in the 350D LC. Large, easy-to-open service doors and grouped service points make quick work of the daily routine. Remote-mounted oil and fuel

filters and extended engine and hydraulic oil service intervals minimize periodic maintenance. Plus a Machine Information Center, diagnostic monitor, and fluid-sample ports help speed preventative maintenance and troubleshooting.

1. Vertical spin-on engine, hydraulic, and fuel filters are positioned in the right rear compartment for simplified servicing.

2. Ground-level fresh-air cab filter is quickly serviced from the cab. Where it's more likely to get done.

3. State-of-the-art multifunction monitor provides scheduled maintenance alerts and diagnostic messages to help defeat downtime.

4. Centralized lube banks place difficult-to-lube zerks within easy reach. Help make greasing less messy and time consuming, too.

5. Remote diagnostic and fluid-sample ports help speed preventative maintenance and troubleshooting.

6. Convenient door atop the hood speeds and simplifies daily engine oil and coolant checks.



Specifications



Engine	350D LC
Type	John Deere 6090H with altitude-compensating turbocharger and air-to-air charge air cooler; meets EPA and CARB emission non-road regulations
Rated Power	271 SAE net hp (202 kW) @ 1,900 rpm
Cylinders	6
Displacement	542 cu. in. (9.0 L)
Maximum Net Torque	1,898 lb.-ft. (1399 Nm) @ 1,300 rpm
Cooling Fan	suction-type, hydraulic-driven, remote-mounted drive
Electrical System	24 volt with 80-amp alternator
Batteries (two 12 volt)	reserve capacity: 180 min.
Off-level capacity	100% (45 deg.)

Hydraulic System

Main Pumps	two variable-displacement axial-piston
Maximum Flow	2 x 76.1 gpm (2 x 288 L/min.)
Pilot Pump	one gear
Maximum Flow	8.9 gpm (34 L/min.)
Pressure Setting	580 psi (4000 kPa)
System Operating Pressure	
Implement Circuits	4,980 psi (34 300 kPa)
Travel Circuits	4,980 psi (34 300 kPa)
Swing Circuits	4,700 psi (32 400 kPa)
Power Boost	5,260 psi (36 300 kPa)
Oil Filtration	one 10-micron full-flow return filter with by-pass / one pilot oil filter

Cylinders

	<i>Bore</i>	<i>Rod Diameter</i>	<i>Stroke</i>
Boom (2)	5.7 in. (145 mm)	3.9 in. (100 mm)	59.8 in. (1520 mm)
Arm (1)	6.7 in. (170 mm)	4.5 in. (115 mm)	68.5 in. (1740 mm)
Bucket (1)	5.5 in. (140 mm)	3.7 in. (95 mm)	49.2 in. (1250 mm)

Swing Mechanism

Swing Speed	0–10.7 rpm
Swing Torque	81,950 lb.-ft. (111 194 Nm)

Undercarriage

Carrier Rollers (per side)	2
Track Rollers (per side)	8
Shoes, Triple Semi-Grouser (per side)	98
Track Guides	front, center, and rear
Track Adjustment	hydraulic
Travel Speed	
Low	0–2.0 mph (0–3.2 km/h)
High	0–3.4 mph (0–5.5 km/h)
Drawbar Pull	67,928 lb. (30 812 kg)

Ground Pressure Data

Average Ground Pressure	
32-in. (800 mm) Triple Semi-Grouser Shoes (recommended for general/soft terrain)	7.16 psi (49.4 kPa)

Capacities (U.S.)

350D LC

Fuel Tank	166 gal. (630 L)
Cooling System	42 qt. (39.7 L)
Engine Lubrication, Including Filter	28.5 qt. (27 L)
Hydraulic Tank	51.5 gal. (195 L)
Hydraulic System	89.8 gal. (340 L)
Propel Gearbox (each)	9 qt. (8.5 L)
Swing Drive	12.5 qt. (11.8 L)

SAE Operating Weights

With Full Fuel Tank; 175-lb. (79 kg) Operator; 2.3-cu.-yd. (1.76 m³), 54-in. (1370 mm), 2,557-lb. (1160 kg) Bucket; 13-ft. 1-in. (4.0 m) Arm; 16,314-lb. (7400 kg) Counterweight; and 32-in. (800 mm) Triple Semi-Grouser Shoes. 77,269 lb. (35 049 kg)

Component Weights

Undercarriage with 32-in. (800 mm) Triple Semi-Grouser Shoes	28,020 lb. (12 710 kg)
One-Piece Boom (with arm cylinder)	6,682 lb. (3031 kg)
Arm with Bucket Cylinder and Linkage	
8 ft. 9 in. (2.66 m)	3,635 lb. (1649 kg)
10 ft. 6 in. (3.2 m)	3,876 lb. (1758 kg)
13 ft. 1 in. (4.0 m)	4,184 lb. (1898 kg)
Boom Lift Cylinders (2) Total Weight	1,248 lb. (624 kg)
2.3-cu.-yd. (1.76 m ³), 54-in. (1370 mm) Heavy-Duty Bucket	2,557 lb. (1160 kg)
Counterweight	16,314 lb. (7400 kg)

Operating Information

	<i>Arm Length 8 ft. 9 in. (2.66 m)</i>	<i>Arm Length 10 ft. 6 in. (3.2 m)</i>	<i>Arm Length 13 ft. 1 in. (4.0 m)</i>
Arm Force with 32-in. (800 mm) Triple Semi-Grouser Shoes*	43,730 lb. (194.5 kN)	38,030 lb. (169.2 kN)	32,682 lb. (145.4 kN)
Bucket Digging Force with 32-in. (800 mm) Triple Semi-Grouser Shoes*	48,220 lb. (241.5 kN)	48,220 lb. (241.5 kN)	48,220 lb. (241.5 kN)
Lifting Capacity Over Front @ Ground Level			
20-ft. (6.1 m) Reach*	27,493 lb. (12 470 kg)	27,598 lb. (12 518 kg)	27,623 lb. (12 530 kg)
A Maximum Reach	34 ft. 8 in. (10.57 m)	36 ft. 5 in. (11.10 m)	38 ft. 11 in. (11.86 m)
A' Maximum Reach @ Ground Level	34 ft. 0 in. (10.36 m)	35 ft. 9 in. (10.89 m)	39 ft. 1 in. (11.97 m)
B Maximum Digging Depth	22 ft. 5 in. (6.84 m)	24 ft. 3 in. (7.38 m)	26 ft. 10 in. (8.18 m)
B' Maximum Digging Depth @ 8-ft. (2.44 m) Flat Bottom	21 ft. 9 in. (6.64 m)	23 ft. 8 in. (7.21 m)	26 ft. 5 in. (8.04 m)
C Maximum Cutting Height	32 ft. 9 in. (9.99 m)	34 ft. 0 in. (10.36 m)	35 ft. 3 in. (10.75 m)
D Maximum Dumping Height	22 ft. 9 in. (6.94 m)	23 ft. 9 in. (7.24 m)	25 ft. 0 in. (7.63 m)
E Minimum Swing Radius	15 ft. 2 in. (4.61 m)	14 ft. 8 in. (4.96 m)	14 ft. 8 in. (4.47 m)
F Maximum Vertical Wall	18 ft. 1 in. (5.51 m)	21 ft. 1 in. (6.42 m)	23 ft. 10 in. (7.27 m)
G Tail Swing Radius	11 ft. 1 in. (3.38 m)	11 ft. 1 in. (3.38 m)	11 ft. 1 in. (3.38 m)

*Digging forces and lift capacities with power boost.

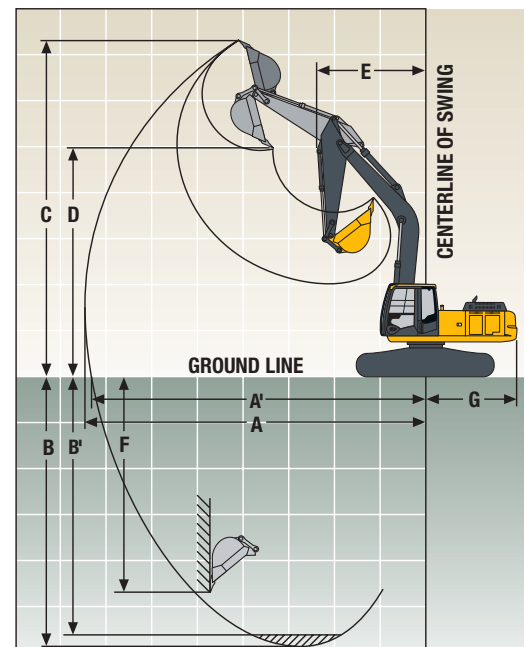

Dimensions

350D LC

- A** 8-ft. 9-in. (2.66 m) arm 11 ft. 5 in. (3.47 m)
 10-ft. 6-in. (3.2 m) arm 10 ft. 9 in. (3.27 m)
 13-ft. 1-in. (4.0 m) arm 11 ft. 10 in. (3.60 m)
- B** 8-ft. 9-in. (2.66 m) arm 36 ft. 6 in. (11.13 m)
 10-ft. 6-in. (3.2 m) arm 36 ft. 1 in. (11.00 m)
 13-ft. 1-in. (4.0 m) arm 36 ft. 5 in. (11.09 m)

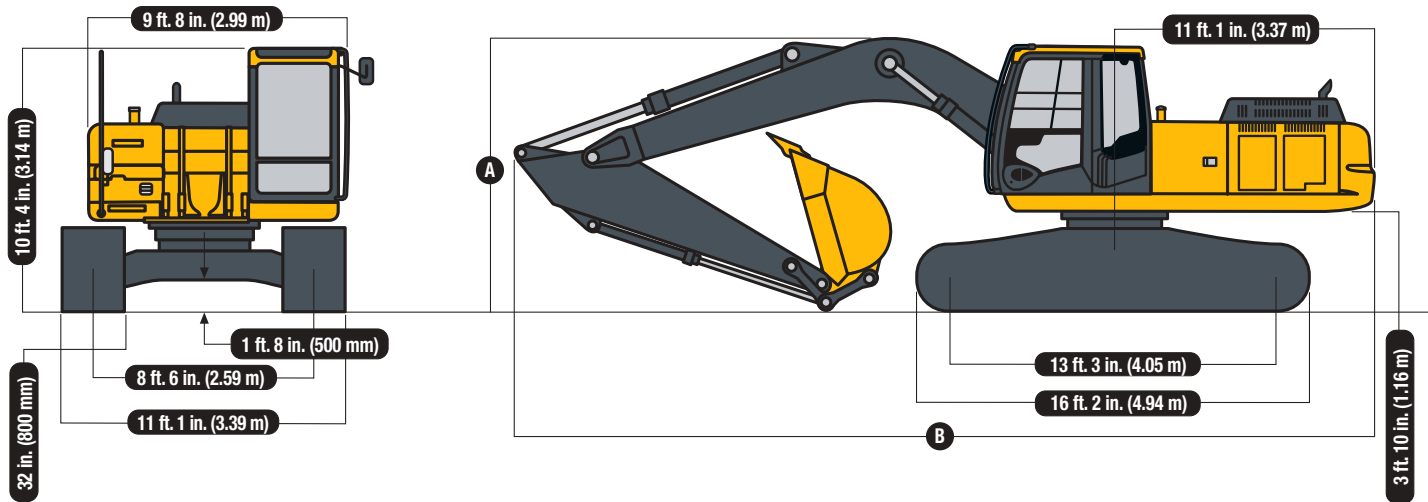

Lift Capacities

Boldface italic type indicates hydraulic-limited capacities; lightface type indicates stability-limited capacities, in lb. (kg). Ratings at bucket lift hook; machine equipped with 2.3-cu.-yd. (1.76 m³), 54-in. (1370 mm), 2,557-lb. (1160 kg) bucket; 16,314-lb. (7400 kg) counterweight; standard gauge; and situated on firm, uniform supporting surface. Total load includes weight of cables, hook, etc. Figures do not exceed 87 percent of hydraulic capacities or 75 percent of weight needed to tip machine. All lift capacities are based on SAE J1097.

Load Point Height	15 ft. (4.57 m)		20 ft. (6.10 m)		25 ft. (7.62 m)		30 ft. (9.15 m)		35 ft. (10.67 m)	
	Over Front	Over Side	Over Front	Over Side	Over Front	Over Side	Over Front	Over Side	Over Front	Over Side
<i>With 13-ft. 1-in. (4.0 m) arm and 32-in. (800 mm) triple semi-grouser shoes</i>										
20 ft. (6.10 m)							12,273 (5567)	9,996 (4534)		
15 ft. (4.57 m)							13,451 (6101)	9,724 (4411)		
10 ft. (3.05 m)	26,701 (12 111)	26,701 (12 111)	19,872 (9014)	18,786 (8521)	16,581 (7521)	12,937 (5868)	14,716 (6675)	9,301 (4219)	10,208 (4630)	6,785 (3078)
5 ft. (1.52 m)	34,222 (15 523)	26,533 (12 035)	24,420 (11 077)	17,264 (7831)	19,101 (8664)	12,116 (5496)	14,871 (6745)	8,838 (4009)	11,358 (5152)	6,557 (2974)
Ground Line	27,003 (12 248)	24,933 (11 310)	27,623 (12 530)	16,161 (7331)	19,411 (8805)	11,440 (5189)	14,433 (6547)	8,436 (3827)	11,143 (5054)	6,356 (2883)
-5 ft. (-1.52 m)	25,662 (11 640)	24,473 (11 101)	27,191 (12 334)	15,588 (7071)	18,937 (8590)	11,014 (4996)	14,147 (6417)	8,174 (3708)		
-10 ft. (-3.05 m)	28,325 (12 848)	24,540 (11 131)	27,018 (12 255)	15,438 (7003)	18,768 (8513)	10,862 (4927)	14,080 (6387)	8,111 (3679)		
-15 ft. (-4.57 m)	32,496 (14 740)	24,977 (11 329)	25,622 (11 622)	15,636 (7092)	18,930 (8587)	11,008 (4993)				
-20 ft. (-6.10 m)	25,530 (11 580)	25,530 (11 580)	19,607 (8894)	16,245 (7369)						
<i>With 10-ft. 6-in. (3.2 m) arm and 32-in. (800 mm) triple semi-grouser shoes</i>										
25 ft. (7.62 m)					10,000 (4536)	10,000 (4536)				
20 ft. (6.10 m)					14,638 (6640)	13,905 (6307)	9,472 (4296)	9,472 (4296)		
15 ft. (4.57 m)					16,151 (7326)	13,371 (6065)	15,044 (6824)	9,511 (4314)		
10 ft. (3.05 m)	32,447 (14 718)	27,999 (12 700)	22,606 (10 254)	18,134 (8226)	18,339 (8319)	12,640 (5733)	15,199 (6894)	9,157 (4154)		
5 ft. (1.52 m)			26,577 (12 055)	16,793 (7617)	19,917 (9034)	11,915 (5405)	14,777 (6703)	8,768 (3977)		
Ground Line	19,237 (8726)	19,237 (8726)	27,598 (12 518)	15,968 (7243)	19,313 (8760)	11,372 (5158)	14,439 (6549)	8,458 (3837)		
-5 ft. (-1.52 m)	18,735 (8498)	18,735 (8498)	27,226 (12 349)	15,646 (7097)	18,999 (8618)	11,091 (5031)	14,276 (6476)	8,309 (3769)		
-10 ft. (-3.05 m)	24,351 (11 046)	24,351 (11 046)	27,279 (12 374)	15,692 (7118)	18,998 (8617)	11,090 (5030)				
-15 ft. (-4.57 m)	29,437 (13 353)	25,623 (11 623)	23,225 (10 535)	16,080 (7294)	17,270 (7834)	11,462 (5199)				
<i>With 8-ft. 9-in. (2.66 m) arm and 32-in. (800 mm) triple semi-grouser shoes</i>										
20 ft. (6.10 m)					16,071 (7290)	13,686 (6208)				
15 ft. (4.57 m)			20,080 (9108)	19,184 (8702)	17,400 (7893)	13,183 (5980)	15,444 (7005)	9,394 (4261)		
10 ft. (3.05 m)			24,277 (11 012)	17,736 (8045)	19,413 (8806)	12,487 (5664)	15,127 (6862)	9,103 (4129)		
5 ft. (1.52 m)			27,773 (12 598)	16,530 (7498)	19,799 (8981)	11,826 (5364)	14,763 (6696)	8,769 (3978)		
Ground Line			27,493 (12 471)	15,899 (7212)	19,292 (8751)	11,370 (5157)	14,497 (6576)	8,525 (3867)		
-5 ft. (-1.52 m)	22,873 (10 375)	22,873 (10 375)	27,301 (12 384)	15,733 (7136)	19,086 (8657)	11,185 (5073)	14,446 (6553)	8,478 (3846)		
-10 ft. (-3.05 m)	19,509 (8849)	19,509 (8849)	26,307 (11 933)	15,900 (7212)	19,213 (8715)	11,299 (5125)				
-15 ft. (-4.57 m)	26,093 (11 836)	26,088 (11 833)	20,977 (9515)	16,439 (7457)						

Buckets

350D LC

A full line of buckets is offered to meet a wide variety of applications. Digging forces are with power boost. Tooth selection includes either the John Deere Fanggs®, Standard, Tiger, Twin Tiger, Abrasion panel, or Flare tooth, or the ESCO (Vertalok) Standard, Tiger, Twin Tiger, or Flare tooth. Replaceable cutting edges are available through John Deere parts. Optional side cutters add 6 inches (150 mm) to bucket widths.

Type Bucket	Bucket Width		Bucket Capacity*		Weight		Bucket Dig Force		Arm Dig Force 8 ft. 9 in. (2.66 m)		Arm Dig Force 10 ft. 6 in. (3.2 m)		Arm Dig Force 13 ft. 1 in. (4.0 m)		Bucket Tip Radius		No. Teeth
	in.	mm	cu. yd.	m ³	lb.	kg	lb.	kN	lb.	kN	lb.	kN	lb.	kN	in.	mm	
General-Purpose Plate Lip	48	1219	2.03	1.55	2,115	959	48,220	214.5	43,730	194.5	38,030	169.2	32,682	145.4	63.0	1600	6
	54	1372	2.30	1.76	2,215	1005	48,220	214.5	43,730	194.5	38,030	169.2	32,682	145.4	63.0	1600	7
	60	1524	2.59	1.98	2,338	1061	48,220	214.5	43,730	194.5	38,030	169.2	32,682	145.4	63.0	1600	7
General-Purpose High Capacity	48	1219	2.15	1.64	2,815	1277	43,712	194.4	42,090	187.2	36,768	163.5	31,747	141.2	69.5	1765	5
	54	1372	2.45	1.87	2,982	1353	43,712	194.4	42,090	187.2	36,768	163.5	31,747	141.2	69.5	1765	6
	60	1524	2.74	2.09	3,089	1401	43,712	194.4	42,090	187.2	36,768	163.5	31,747	141.2	69.5	1765	7
Heavy-Duty Plate Lip	36	914	1.48	1.13	2,138	970	48,220	214.5	43,730	194.5	38,030	169.2	32,682	145.4	63.0	1600	4
	42	1067	1.75	1.34	2,210	1002	48,220	214.5	43,730	194.5	38,030	169.2	32,682	145.4	63.0	1600	5
	48	1219	2.03	1.55	2,324	1054	48,220	214.5	43,730	194.5	38,030	169.2	32,682	145.4	63.0	1600	6
	54	1372	2.30	1.76	2,557	1160	48,220	214.5	43,730	194.5	38,030	169.2	32,682	145.4	63.0	1600	6
Heavy-Duty High Capacity	30	762	1.26	0.96	2,516	1141	43,712	194.4	42,090	187.2	36,768	168.5	31,747	141.2	69.5	1765	4
	36	914	1.56	1.19	2,781	1261	43,712	194.4	42,090	187.2	36,768	168.5	31,747	141.2	69.5	1765	4
	42	1067	1.85	1.41	3,120	1415	43,712	194.4	42,090	187.2	36,768	168.5	31,747	141.2	69.5	1765	5
	48	1219	2.15	1.64	3,318	1505	43,712	194.4	42,090	187.2	36,768	168.5	31,747	141.2	69.5	1765	6
	54	1372	2.45	1.87	3,562	1616	43,712	194.4	42,090	187.2	36,768	168.5	31,747	141.2	69.5	1765	6

*All capacities are SAE heaped ratings and with side cutters.

Bucket Selection Guide*

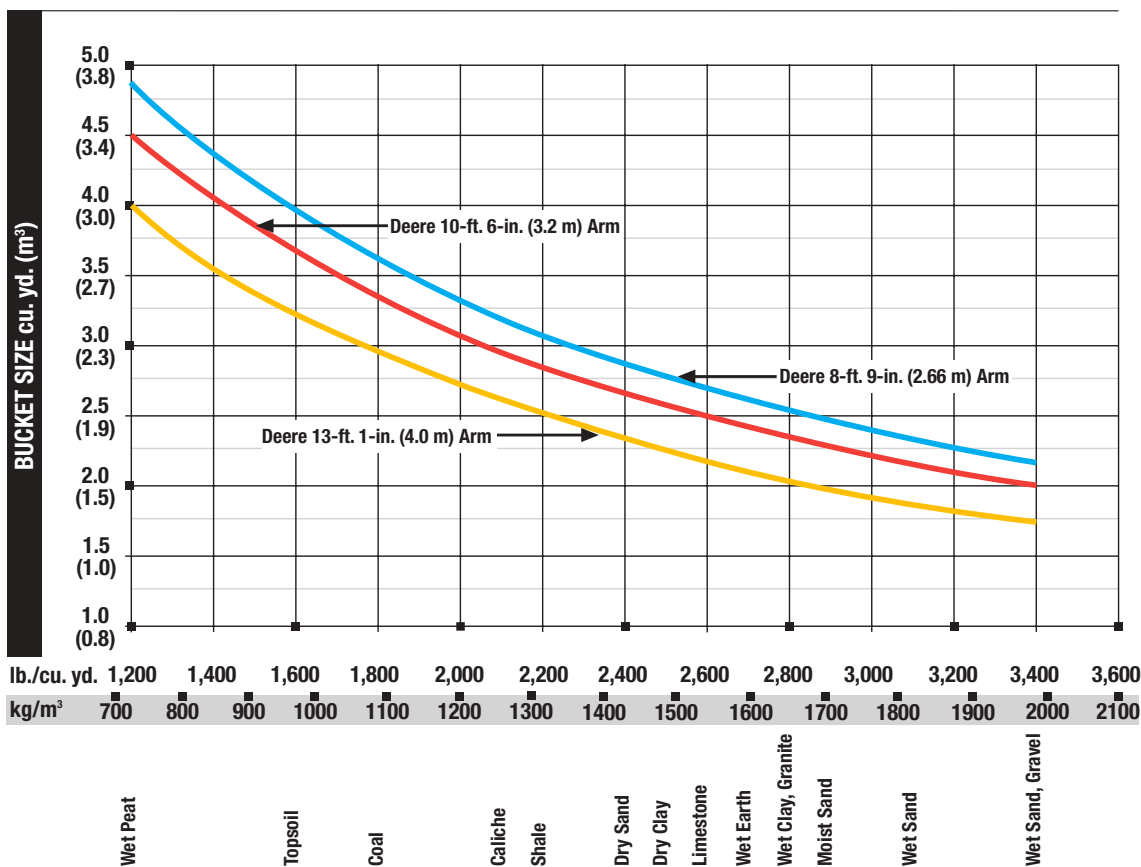

*Contact your John Deere dealer for optimum bucket and attachment selections. These recommendations are for general conditions and average use. Does not include optional equipment such as thumbs or couplers. Larger buckets may be possible when using light materials, for flat and level operations, less compacted materials, and volume loading applications such as mass excavation applications in ideal conditions. Smaller buckets are recommended for adverse conditions such as off-level applications, rocks, and uneven surfaces. Bucket capacity indicated is SAE heaped.

350D LC EXCAVATOR

Key: ● Standard equipment ▲ Optional or special equipment

*See your John Deere dealer for further information.

350D Engine

- Meets EPA and CARB emission non-road regulations
- Auto-idle system
- Automatic belt tension device
- Batteries (two 12 volt), 180-min. reserve capacity
- Coolant recovery tank
- Dual-element dry-type air filter
- Electronic engine control
- Enclosed fan guard (conforms to SAE J1308)
- Engine coolant to -34°F (-37°C)
- Fuel filter with water separator
- Full-flow oil filter
- Turbocharger with charge air cooler
- Muffler, under hood, with vertical curved end exhaust stack
- Cool-on-demand hydraulic-driven fan
- 500-hour engine-oil-change interval
- 100% (45 deg.) off-level capability
- Engine-oil-sampling valve
- ▲ Electric ether starting aid
- ▲ Hydraulic fan reverser
- ▲ Engine coolant heater

Hydraulic System

- Reduced-drift valve for boom down, arm in
- Auxiliary hydraulic valve section
- Spring-applied, hydraulically released automatic swing brake
- Auxiliary hydraulic-flow adjustments through monitor
- Auto power lift
- 5,000-hour hydraulic-oil-change interval
- Hydraulic-oil-sampling valve
- ▲ Auxiliary hydraulic lines
- ▲ Auxiliary pilot and electric controls
- ▲ Hydraulic filter restriction indicator kit
- ▲ Load-lowering control device
- ▲ Single-pedal propel control
- ▲ Control pattern change valve

Undercarriage

- Planetary drive with axial piston motors
- Propel motor shields
- Spring-applied, hydraulically released automatic propel brake
- Track guides, front idler and three additional
- Two-speed propel with automatic shift
- Upper carrier rollers (2)
- Sealed and lubricated track chain
- Triple semi-grouser shoes, 32 in. (800 mm)

350D Upperstructure

- Right- and left-hand mirrors
- Vandal locks with ignition key: Cab door / Fuel cap / Service doors / Toolbox
- Debris-screening side panel
- Remote-mounted engine oil and fuel filters

Front Attachments

- Centralized lubrication system
- Dirt seals on all bucket pins
- Less boom and arm
- Oil-impregnated bushings
- Reinforced resin thrust plates
- Tungsten carbide thermal coating on arm-to-bucket joint
- ▲ Arm, 8 ft. 9 in. (2.66 m)
- ▲ Arm, 10 ft. 6 in. (3.2 m)
- ▲ Arm, 13 ft. 1 in. (4.0 m)
- ▲ Attachment quick-couplers
- ▲ Boom cylinder with plumbing to mainframe for less boom and arm
- ▲ Bucket-to-arm clearance adjustable bushing (except ditching buckets)
- ▲ Buckets: General purpose / General-purpose high capacity / Heavy duty / Heavy-duty high capacity / Side cutters and teeth
- ▲ Material clamps
- ▲ Super-long fronts

Operator's Station

- Adjustable independent control positions (levers-to-seat, seat-to-pedals)
- AM/FM radio
- Auto climate control/air conditioner, 20,000 Btu/hr. (5.9 kW) with heater and pressurizer
- Built-in Operator's Manual storage compartment and manual
- Cell-phone power outlet, 12 volt, 60 watt, 5 amp
- Coat hook
- Deluxe suspension cloth seat with 4-in. (100 mm) adjustable armrests
- Floor mat
- Front windshield wiper with intermittent speeds
- Gauges (illuminated): Engine coolant / Fuel
- Horn, electric
- Hourmeter, electric
- Hydraulic shutoff lever, all controls
- Hydraulic warm-up control

350D Operator's Station (continued)

- Interior light
- Large cup holder
- Machine Information Center (MIC)
- Mode selectors (illuminated): Power modes – three / Travel modes – two with automatic shift / Work mode – one
- Multifunction, color LCD monitor with: Diagnostic capability / Multiple-language capabilities / Maintenance tracking / Clock / Theft-deterrent system / System monitoring with alarm features: Auto-idle indicator, engine air cleaner restriction indicator light, engine check, engine coolant temperature indicator light with audible alarm, engine oil pressure indicator light with audible alarm, low-alternator-charge indicator light, low-fuel indicator light, fault code alert indicator, fuel-rate display, wiper-mode indicator, work-lights-on indicator, and work-mode indicator
- ▲ Monitor system with alarm features: Hydraulic oil filter restriction indicator light
- Motion alarm with cancel switch (conforms to SAE J994)
- Power-boost switch on right console lever
- Auxiliary hydraulic control switches in right console lever
- SAE two-lever control pattern
- Seat belt, 2 in. (51 mm), retractable
- ▲ Seat belt, 3 in. (76 mm), non-retractable
- Tinted glass
- Transparent tinted overhead hatch
- Hot/cold beverage compartment
- ▲ Air-suspension heated seat
- ▲ 24- to 12-volt D.C. radio convertors, 10 amp
- ▲ Circulation fan
- ▲ Protection screens for cab front, rear, and side
- ▲ Window vandal protection covers

Electrical

- 80-amp alternator
- Blade-type multi-fused circuits
- Positive terminal battery covers
- ▲ Cab extension wiring harness

Lights

- Work lights: Halogen / One mounted on boom / One mounted on frame

CONTROL OWNING AND OPERATING COSTS

Customer Personal Service (CPS) is part of John Deere's proactive, fix-before-fail strategy on machine maintenance that will help control costs, increase profits, and reduce stress. Included in this comprehensive lineup of ongoing programs and services are:

Fluid analysis program – tells you what's going on inside *all* of your machine's major components so you'll know if there's a problem *before* you see a decline in performance. Fluid analysis is included in most extended coverage and preventive-maintenance agreements.

Component life-cycle data – gives you vital information on the projected life span of components and lets you make informed decisions on machine maintenance by telling you approximately how many hours of use you can expect from an engine, transmission, or hydraulic pump. This information can be used to preempt catastrophic downtime by servicing major components at about 80 percent of their life cycle.

Preventive Maintenance (PM) agreements – give you a fixed cost for maintaining a machine for a given period of time. They also help you avoid downtime by ensuring that

critical maintenance work gets done right and on schedule. On-site preventive maintenance service performed where and when you need it helps protect you from the expense of catastrophic failures and lets you avoid waste-disposal hassles.

Extended coverage – gives you a fixed cost for machine repairs for a given period of time so you can effectively manage costs. Whether you work in a severe-service setting or just want to spread the risk of doing business, this is a great way to custom-fit coverage for your operation. And an extended coverage contract also travels well because it's backed by John Deere and is honored by *all* Deere construction dealers.

Customer Support Advisors (CSAs) – Deere believes the CSA program lends a *personal* quality to Customer Personal Service (CPS). Certified CSAs have the knowledge and skills for helping make important decisions on machine maintenance and repair. Their mission is to help you implement a plan that's right for *your* business and take the burden of machine maintenance off your shoulders.



JOHN DEERE

DKAX350DLC Litho in U.S.A. (06-04)

Net engine power is with standard equipment including air cleaner, exhaust system, alternator, and cooling fan, at standard conditions per SAE J1349 and DIN 6270B, using No. 2-D fuel at 35 API gravity. No derating is required up to 10,000-ft. (3050 m) altitude. Gross power is without cooling fan.

Specifications and design subject to change without notice. Wherever applicable, specifications are in accordance with SAE standards. Except where otherwise noted, these specifications are based on a unit with 54-in. (1370 mm) bucket, 32-in. (800 mm) triple semi-grouser shoes, 16,314-lb. (7400 kg) counterweight, full fuel tank, and 175-lb. (79 kg) operator.

